

INSTANT-TEMP® - LOW FLOW

APPLICATION: commercial, industrial, residential, multiple lavatories, public lavatories, kitchen/bar sink

PRODUCT FEATURES

- Uses a digital microprocessor for temperature control
Ultra quick response times for temperature variations - 120 times per second. Microprocessor use is the most energy efficient means of heating water
- Unlimited hot water
- Ideal for sensor /hands-free faucets with the 104°F factory preset setting; no mixing valve needed
- Saves water and energy - 99% energy efficient
- Works on low flow
- Rugged steel housing
- Space saving compact size: 7-5/16" (H) x 10-3/4" x 2-3/4"
- Meets applicable building codes including ADA, UL, IAPMO, UPC.
- Environmentally friendly
- Made in the U.S.A.
- Field Adjustable



Instant-Temp® - Low Flow

Chronomite Instant-Temp® - Low Flow models are manufactured to provide reliable point-of-use hot water at 0.5 gallon per minute with a minimum pressure of 45 PSI. There is no pressure and temperature relief valve needed (unless required by code), saving time and money on installation.

Housing is fabricated from rugged steel.

Element assembly is fabricated from Celcon plastic.

Coils are nichrome.

Flow control and compression fittings are supplied with each unit.

GUIDE SPECIFICATION

Tankless Water Heater shall be a Chronomite Laboratories Model

E - _____ L / _____

x 100 WATTS VOLTS OPTIONS

with _____ Amps and _____ Volts

to heat 0.5 gpm to a preset temperature of:

- 104°F (Standard sensor faucet hand washing setting)
- 110°F (Standard hand washing setting) (Meets ADA)
- Other temperature settings available upon request (specify below)
- 120°F (Meets health code)

Unit shall be provided with Celcon waterways, and Nichrome heating coils. Hot water storage vessel and simple analog temperature controller are expressly prohibited.

OPTIONS

- Factory Preset (F)
- Remote Accessory (R)
- Satin Finish Stainless Steel (SS)
- High Polish Finish Stainless Steel (SSP)
- Low Flow (LLP)
- De-ionized (DI)
- Multiple Lav applications (FLLP)

Model E-46L/240 with 21 Amps, 240 Volts heat 0.5 gpm to preset temperature of 104°F.

MODEL	AMPS	VOLTAGE	WATTS	TEMP RISE @ 0.5 GPM
E-46L/208	22	208	4,600	63°F
E-46L/240	19	240	4,600	63°F
E-46L/277	17	277	4,600	63°F
E-60L/208	29	208	6,000	82°F
E-60L/240	25	240	6,000	82°F
E-60L/277	22	277	6,000	82°F
E-70L/208	34	208	7,000	96°F
E-70L/240	29	240	7,000	96°F
E-70L/277	25	277	7,000	96°F
E-80L/208	38	208	8,000	See note on pg 2 **
E-80L/240	33	240	8,000	See note on pg 2 **
E-80L/277	29	277	8,000	See note on pg 2 **
E-90L/240	38	240	9,000	See note on pg 2 **
E-90L/277	32	277	9,000	See note on pg 2 **

For the model being selected, please place the corresponding amps and volts values in the Guide Specifications to the right.



CHRONOMITE LABORATORIES, INC.
 17451 Hurley St. :: City of Industry, CA 91744
 Phone 800-447-4962 :: 626-937-4270
 Fax 626-937-4279 :: www.chronomite.com

INSTANT-TEMP[®] - LOW FLOW

TECHNICAL DIMENSIONS

INSTANT-TEMP - LOW FLOW

Dimensions:	7-5/16" (H) x 10-3/4" x 2-3/4"
Weight:	8 lbs.
Materials:	Rugged steel housing Celcon plastic element assembly with nichrome coils
Housing Color:	White
Minimum Operating Flow Rate:	0.5 GPM
Minimum Operating Pressure:	45 PSI
Maximum Operating Pressure:	150 PSI
Maximum Operating Temperature:	140°F
Listing:	UL, IAPMO, UPC, ADA

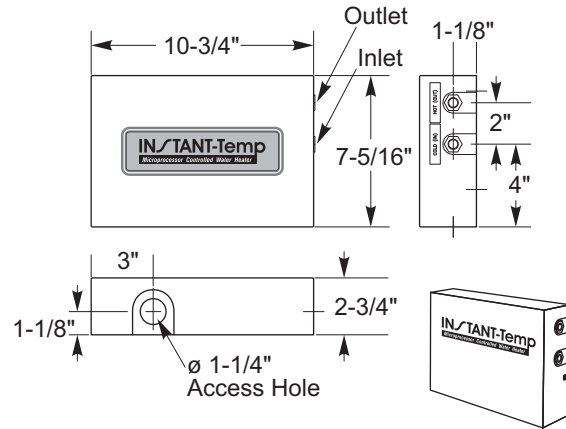

GENERAL NOTES:

- The microprocessor adjusts the heater's power for variations in flow rates, inlet water temperature and pressure to assure the selected factory pre set water temperature. **
- 240V models when operated at 220V will have approximately a 15% wattage decrease.
- Instant-Temp is ideal for sensor/hands-free faucets with the 104°F factory preset setting temperature ; no mixing valve needed

- Factory setting of 110°F or above require cold water mixing at the hand wash faucet.
- Microprocessor limits temperature increase according to the pre-selected temperature

INSTALLATION DIAGRAM

Note: Heater to be installed below the level of all hot water outlets serviced by the heater

Shown installed in a Multi-Lavatory Installation

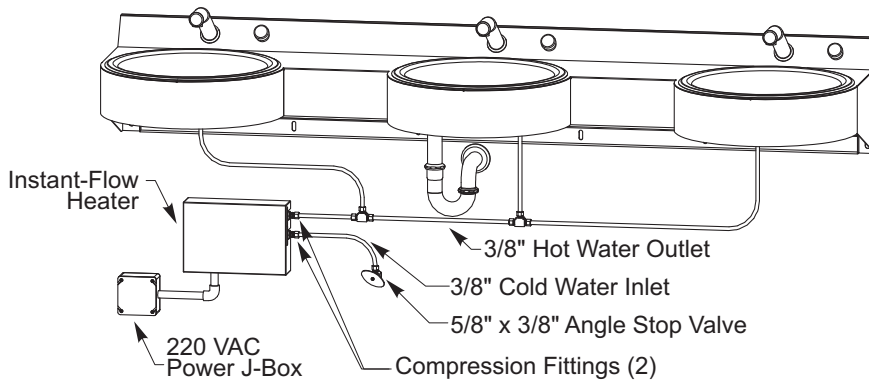

WIRING CONNECTION

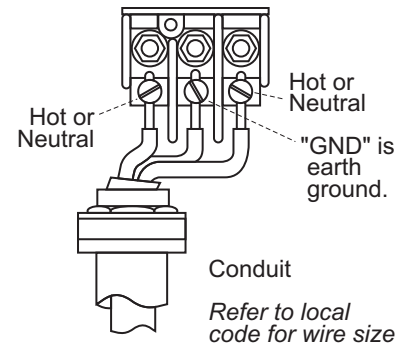

ATTENTION:

Unit must be hard wired.
NOTE: Heaters are single phase.
All tests are measured at the output of the heater.

Chronomite Laboratories assumes no responsibility for use of void or suspended data. © Copyright 2009 Chronomite Laboratories, Inc. City of Industry, CA Chronomite is a Division of Acorn Engineering Company. Please visit www.chronomite.com for most current specifications.

SELECTION SUMMARY & APPROVAL FOR MANUFACTURING

Company _____

Model Number & Options _____ Quantity _____

Contact _____ Title _____

Signature (Approval for Manufacturing) _____ Date _____

CHRONOMITE
LABORATORIES, INC.

PH. 800-447-4962

626-937-4270

FAX 626-937-4279

www.chronomite.com