



ELECTRIC TANKLESS WATER HEATER - LARGE CAPACITY

ER SERIES - TWINS™ - LOW ACTIVATION

IDEAL APPLICATIONS: Shower, Whole Home, Mop Sink

PRODUCT FEATURES

- Uses a digital microprocessor for temperature control
Ultra quick response times for temperature variations - 120 times per second. Microprocessor use is the most energy efficient means of heating water
- Unlimited hot water
- Ideal for sensor /hands-free faucets, no mixing valve needed
- Saves water and energy - 99% energy efficient
- Works on low flow
- Rugged steel housing (Standard)
- Space saving compact size:
15-1/4" x 17-1/2" x 6-1/4"
- Meets applicable building codes including UL, UPC.
- Environmentally friendly
- Made in the U.S.A.
- User adjustable temperature 70°F-125°F (Standard)
- Optional factory preset temperature available, Select single temperature between 90°F-160°F
- Multiple applications handled with one heater

Chronomite Instant-Temp® - High Capacity - Low Activation - L2 models are manufactured to provide reliable point-of-use hot water with flow rate from 0.35 gpm to 4.0 gpm. There is no pressure and temperature relief valve needed (unless required by code), saving time and money on installation.

Housing is fabricated from rugged Jet-Kote® grey steel.

Element assembly is fabricated from Celcon plastic.

Heating Coils are nichrome.

For the model being selected, please place the corresponding amps, volts and watts values in the Guide Specifications above.



GUIDE SPECIFICATION

Tankless Water Heater shall be a Chronomite Laboratories Model

ER - _____ L / _____ - _____
AMPS VOLTS WATTS

with _____ Amps and _____ Volts

Unit shall be provided with Celcon waterways, and Nichrome heating coils. Temperature controlled by microprocessor.

OPTIONS

- Satin Finish Stainless Steel Housing (SS)
- NEMA 4 Cabinet (N4)
- De-ionized (DI)
- Factory Preset (F)
- Stainless Steel Enclosure (N4X)
- Digital Readout (DR)
- Y - Strainer (Y)
- Disconnect Switch Twins Single Phase (2095-2)

MODEL	CIRCUITS	TOTAL AMPS	1 Ø VOLTAGE	WATTS	ACTIVATION GPM	TEMP RISE @ 2.0 GPM	TEMP RISE @ 2.5 GPM	TEMP RISE @ 3.0 GPM
ER-60L/208_12500	2	60 (2 x 30)	208	12500	0.35	43	34	28
ER-60L/240_14400	2	60 (2 x 30)	240	14400	0.35	49	39	33
ER-60L/277_16600	2	60 (2 x 30)	277	16600	0.35	57	45	38
ER-80L/208_16600	2	80 (2 x 40)	208	16600	0.35	57	45	38
ER-80L/240_19200	2	80 (2 x 40)	240	19200	0.35	66	52	44
ER-80L/277_22200	2	80 (2 x 40)	277	22200	0.35	76	61	50



Member of U.S. Green Building Council



Water Conserving Product



Made in the USA

Complies with Standards for:

LISTED TO:
UL STD 499
IEC/EN 60335-1
IEC/EN 60335-2-35

CERTIFIED TO:
CAN/CSA STD C22.2 No. 88



CHRONOMITE LABORATORIES, INC.
 17451 Hurley St. :: City of Industry, CA 91744
 Phone 800-447-4962 :: 626-937-4270
 Fax 626-937-4279 :: www.chronomite.com

MEMBER OF



ER SERIES - TWINS™ - LOW ACTIVATION

TECHNICAL DIMENSIONS

INSTANT-TEMP - HIGH CAPACITY - LOW ACTIVATION

Dimensions:	15-1/4" x 17-1/2" x 6-1/4"
Weight:	24 LBS
Materials:	Rugged steel housing Celcon plastic element assembly with nichrome coils
Minimum Operating Flow Rate:	0.35 GPM
Minimum Pressure:	25 PSI
Maximum Operating Pressure:	80 PSI
Maximum Pressure	150 PSI
Maximum Operating Temperature:	160°F
Listing:	UL, UPC

GENERAL NOTES:

- The microprocessor adjusts the heater's power for variations in flow rates, inlet water temperature and pressure to assure the selected water temperature.
- 240V models when operated at 220V will have approximately a 15% wattage decrease.
- 60-80 amp single phase units use qty 2 circuits

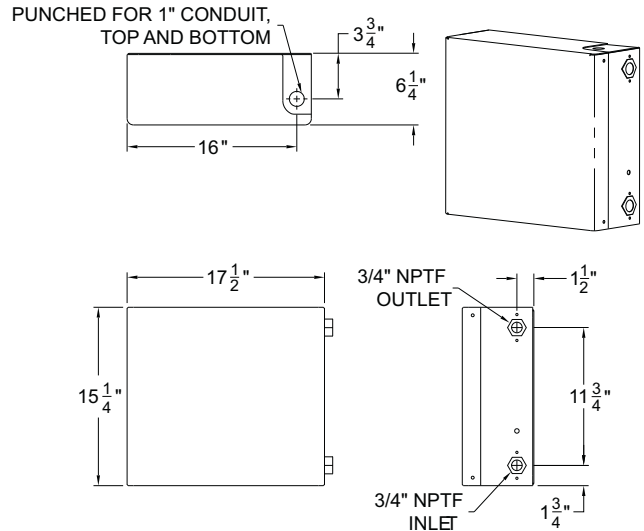

INSTALLATION DIAGRAM

Shown Installed with (2) Two Station Meridian Lavays

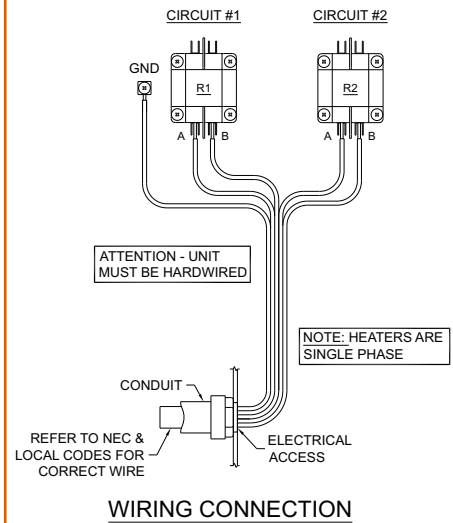
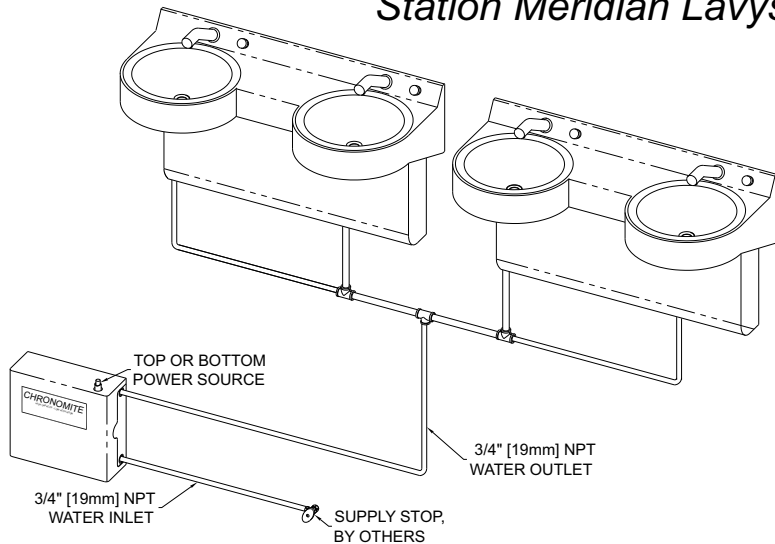

Chronomite Laboratories assumes no responsibility for use of void or suspended data. © Copyright Chronomite Laboratories, Inc. Acorn Family of Companies, City of Industry, CA Please visit www.chronomite.com for most current specifications.

SELECTION SUMMARY & APPROVAL FOR MANUFACTURING

Company _____

Model Number & Options _____ Quantity _____

Contact _____ Title _____

Signature (Approval for Manufacturing) _____ Date _____

CHRONOMITE
LABORATORIES, INC.
PH. 800-447-4962
626-937-4270
FAX 626-937-4279
www.chronomite.com